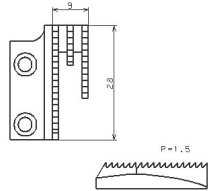
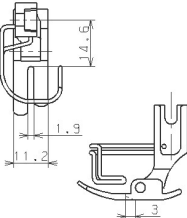
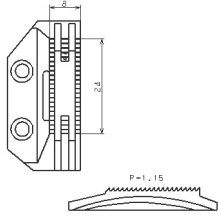
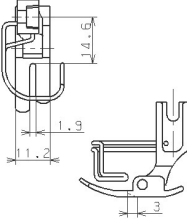
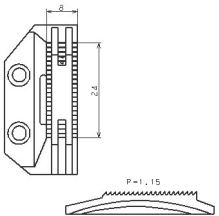
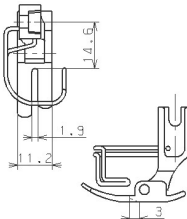
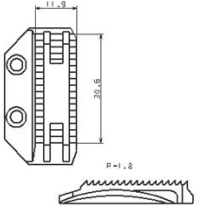
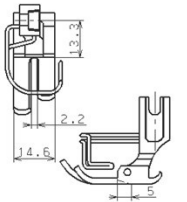
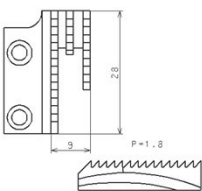
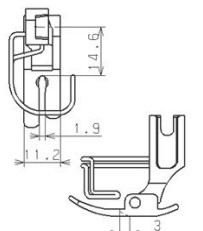
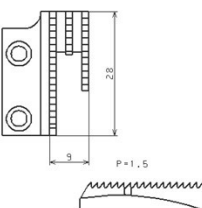
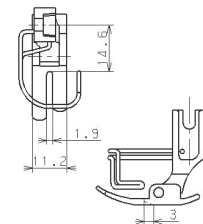
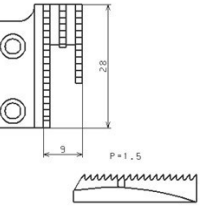
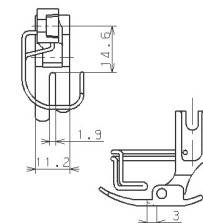
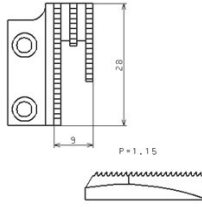
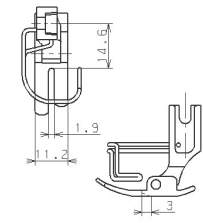
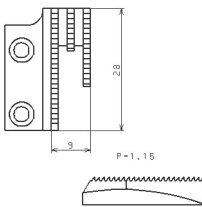
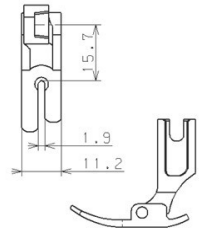
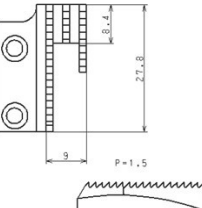
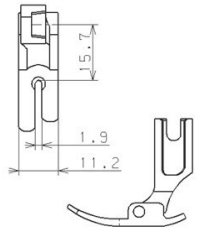
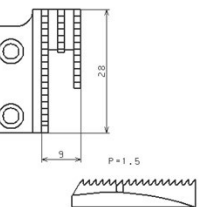
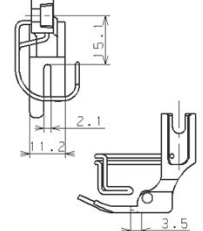
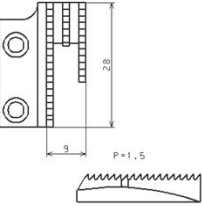
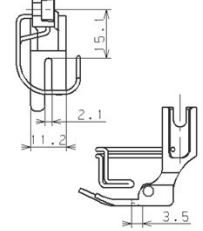
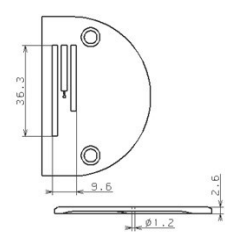
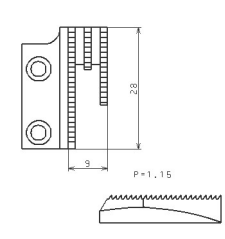
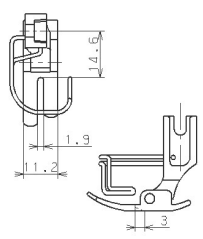
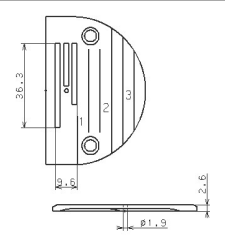
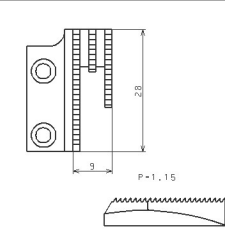
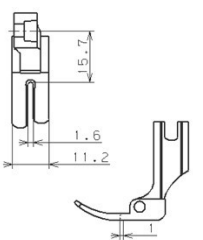
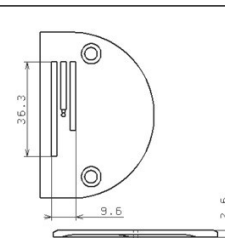
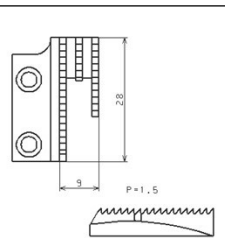
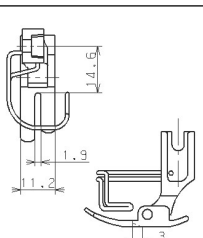
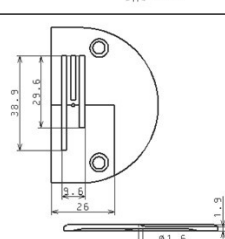
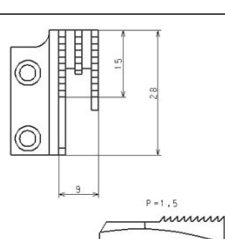
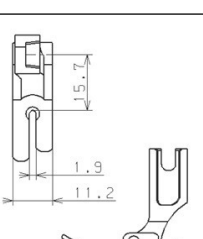
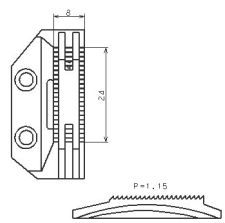
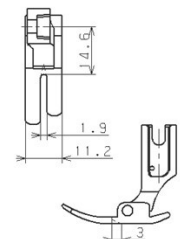
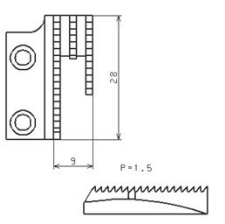
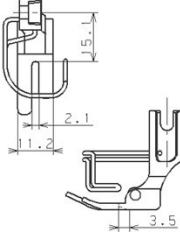
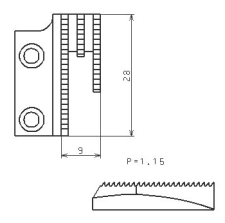
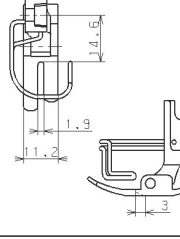
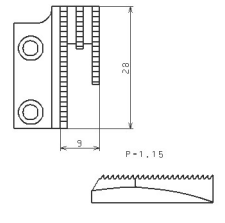
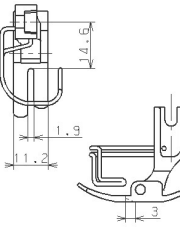

C/N	针板		传送齿		压脚(组件)		注释
	品号	形状	品号	形状	品号	形状	
1	1301	11028008	23614506		B15240120BA		面向日本的标准、 针板以毫米表示
2	1302	B110901210B	B1613012100		B15240120BA		面向一般出口、 欧州的标准、 针板以毫米表示
3	1303	40182291	B1613012100		B15240120BA		面向中国的标准、 针板以毫米表示
4	1304	40089605	11403003		D1524555EBL		面向一般出口、 欧州、 日本的H规格标准

C/N	针板		传送齿		压脚(组件)		注释
	品号	形状	品号	形状	品号	形状	
5	1305	11062007	11062601		40064839		9000C 面向中国的H规格标准
6	1306	B1109012A00	B1613012A00		B15240120BA		针板 雾铬电镀
7	1307	B1109012A0F	B1613012A00		B15240120BA		针板B1109012A00方格毫米表示 (1.0mm间隔)
8	1308	11028008	B1613012B00		B15240120BA		针板毫米表示 传送间距 1.15mm (适合于容易受伤的布料)

C/N	针板		传送齿		压脚(组件)		注释
	品号	形状	品号	形状	品号	形状	
9	1309	B1109012F00	B1613012B00		B1524012TA0		针板雾铬电镀、压脚背面没有避让(收线会变松)
10	1310	B1109012T0B	B1613012T00		B1524012TA0		中央传送较短(容易出现空环) 压脚背面没有避让(收线变松)
11	1311	B1109012B00	B1613012A00		B15245520BA		针板雾铬电镀、压脚收线效果好
12	1312	B1109012E00	B1613012A00		B15245520BA		针板避让 孔的后面 1.6mm 雾铬电镀 可使压脚收线效果好

C/N	针板		传送齿		压脚(组件)		注释
	品号	形状	品号	形状	品号	形状	
13	1313	D1109126W00 	B1613012B00 	B15240120BA 	针板雾铬电镀、防止皱折		
14	1314	11028008 	B1613012B00 	D1524555BA0 	针板毫米表示、压脚避让1mm (收线较松)		
15	1315	11001708 	B1613012A00 	B15240120BA 	针板的 针孔后避让大 (收线效果好)、雾铬电镀		
16	1316	B1109012A0C 	B1613012A0C 	B1524012TA0 	针板近前有加工 仅传送齿后面 (从布料端缝制容易) 压脚背面没有避让 (收线会变松)		

C/N	针板		传送齿		压脚(组件)		注释
	品号	形状	品号	形状	品号	形状	
17	1317	B1109012I0B	B1613012I00		11028156		在压脚S标准形状上 雾铬电镀件 (光滑性好)
18	1318	B1109012B0F	B1613012A00		B15245520BA		B1109012B00上以毫米方格表示 (1.0 mm间隔) 压脚收线效果好
19	1319	B1109012F00	B1613012B00		B15240120BA		针板雾铬电镀、传送间距小
20	1320	B1109012F0F	B1613012B00		B15240120BA		针板B1109012F00方格以毫米表示 (1.0 mm间隔)

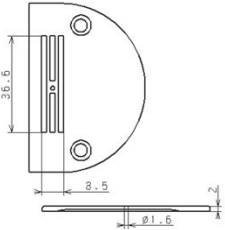
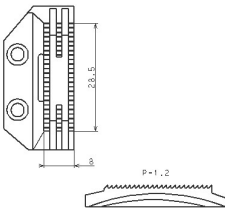
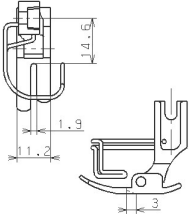
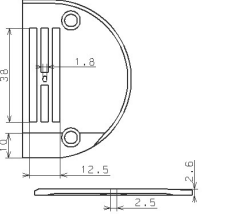
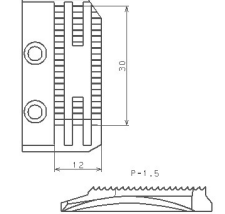
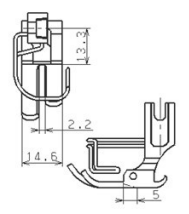
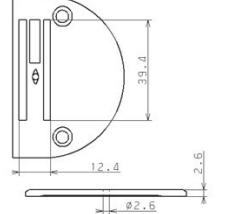
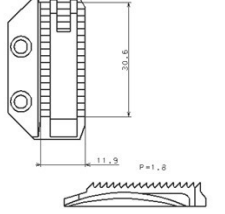
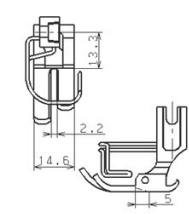
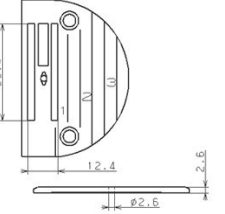
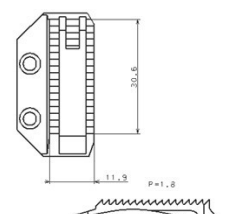
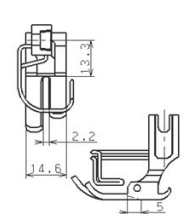
C/N	针板		传送齿		压脚(组件)		注释
	品号	形状	品号	形状	品号	形状	
21	1321 B1109555C00		B1613555C00		B15240120BA		针板雾铬电镀、传送齿全长较长（直进性好）
22	1322 B1109555D00		B1613555D00		D1524555EBL		针板雾铬电镀、针孔由于是1.8×2.5mm的长孔，收线效果好
23	1323 B1109555H0B		B1613555H00		D1524555EBL		3个齿旧H型 标准针位套件
24	1324 11074101		B1613555H00		D1524555EBL		在B1109555H0B上追加了针板刻线（以毫米表示）的部件

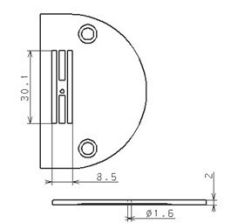
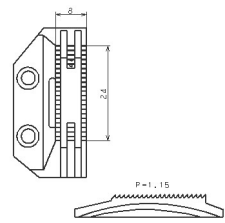
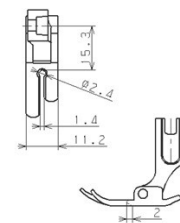
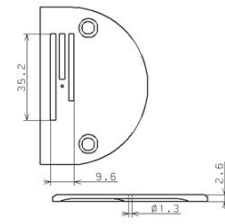
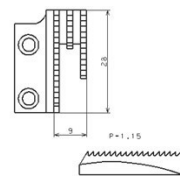
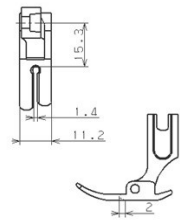
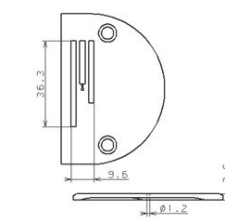
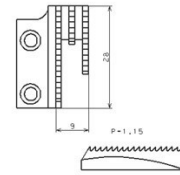
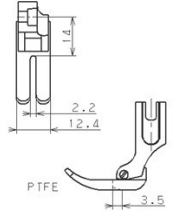
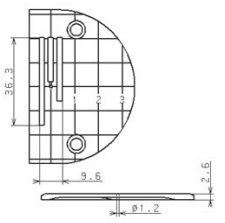
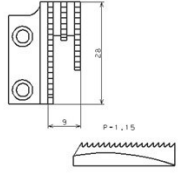
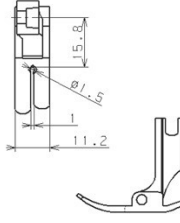
C/N	针板		传送齿		压脚(组件)		注释	
	品号	形状	品号	形状	品号	形状		
25	1325	B1109555I0N		B1613012I00		B1524555DAN		在针板、压脚上 帆布衣裤处理 (光滑性好)
26	1326	B1109555R00		B1613555R00		D1524555DA0		压脚避让小、 有防止起皱的效果
27	1327	D1109126W00		B1613555R00		D1524126WA0		针板雾铬电镀、压脚特氟龙树脂 (光滑性好)
28	1328	D1109126W0F		B1613555R00		D1524155WA0		针板D1109126W00上以毫米方格表示 (1.0mm间隔)、压脚针沟1mm、有防止起皱效果

C/N	针板		传送齿		压脚(组件)		注释
	品号	形状	品号	形状	品号	形状	
29	1329	D1109155W00	D1613155W00		D1524126WBA		针板雾铬电镀、传送齿间距 2.5 mm 以下用 压脚特氟龙树脂 (光滑性好)
30	1330	D1109155W00	D1613155W00		D1524155WA0		针板雾铬电镀、传送齿 间距 2 mm 以下用、压脚针沟 1 mm 起皱性好
31	1331	D1109155W0F	D1613155W00		D1524126WA0		针板D1109155W00上以毫米方格表示 (1.0 mm 间隔)、 传送齿小间距用、压脚特氟龙树脂
32	1332	D1109555D0W	D1613155W00		D1524555DA0		传送齿间距 2.5 mm 以下用、压脚避让 2 mm 防止起皱

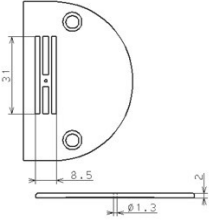
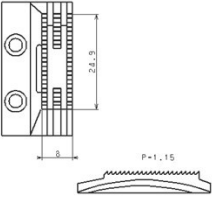
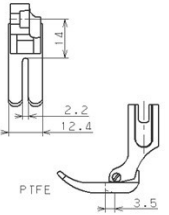
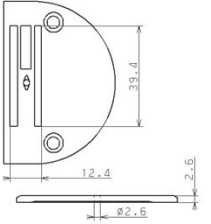
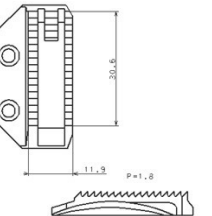
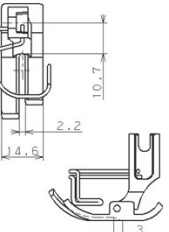
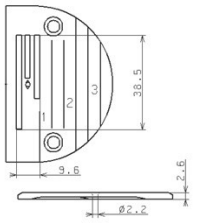
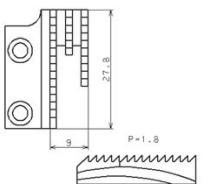
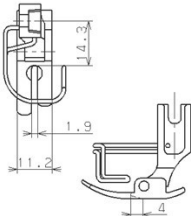
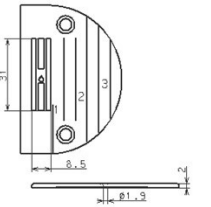
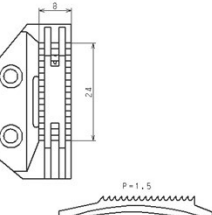
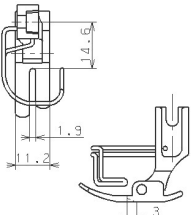
C/N	针板		传送齿		压脚(组件)		注释
	品号	形状	品号	形状	品号	形状	
33	1333	D1109555D0W 	D1613155W00 	D1524126WA0 	传送齿间距 2.5 mm以下用、压脚特氟龙树脂 (光滑性好)		
34	1334	B1109555H0B 	B1613555H00 	B1524041E0 	压脚的落针点后的避让特大 (面向长间距)		
35	1335	11080009 	11080603 	11080371 	针板雾铬电镀、针孔前后有避让 压脚避让4mm (收线效果好)		
36	1336	40182291 	40133950 	B15240120BA 	M型 比4个齿标准针位的收线传力好		

C/N	针板		传送齿		压脚(组件)		注释
	品号	形状	品号	形状	品号	形状	
37	1337 B1109555000		B1613555A00		B15240120BA		针板雾铬电镀、 针孔1.8×2.7mm、传送齿1.6-3.2-2.6mm (右传送齿 宽度小)
38	1338 B1109555000		B1613555B00		B15240120BA		针板雾铬电镀、 针孔1.8×2.7mm、传送齿1.6-3.2-2.6mm (右传送齿 宽度小)
39	1339 11001906		D1613155W00		D1524555DBA		针板以毫米表示 雾铬电镀 传送齿间距2.5mm以下用
40	1340 B1109552000		40133950		B15240120BA		针板以英寸表示、具有小避让, 收线效果好

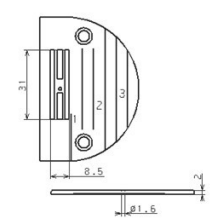
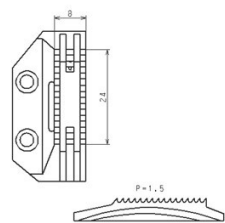
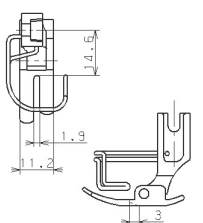
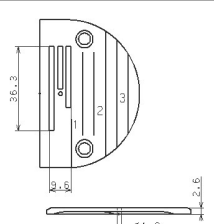
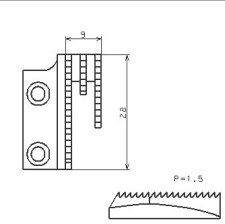
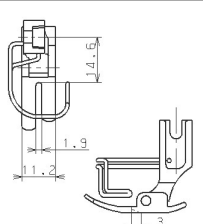
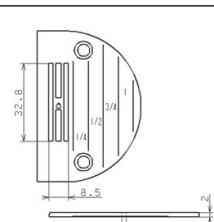
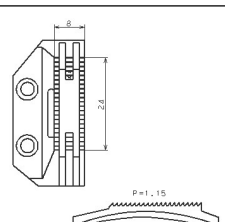
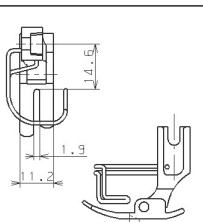
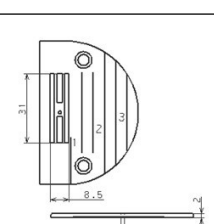
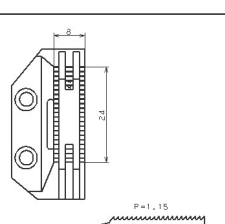
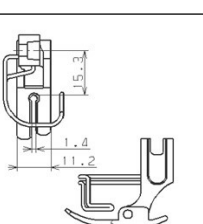
C/N	针板		传送齿		压脚(组件)		注释
	品号	形状	品号	形状	品号	形状	
41	1341 B110901210B		40133950		B15240120BA		针板以毫米表示、 传送齿 传力提高
42	1342 11028008		B1613012A00		B15240120BA		针板以毫米表示 传送齿DDL8700 - 7用 (类似23614506)、材质S15C、 切线避让大
43	1343 B1109552000		B1613012100		B15240120BA		面向一般出口、中国、美国标准 、针板以英寸表示
44	1344 B110901210B		B1613012100		D1524555DBA		面向日本薄料规格标准、 针板以英寸表示 、压脚避让小

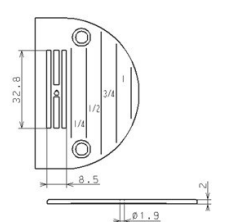
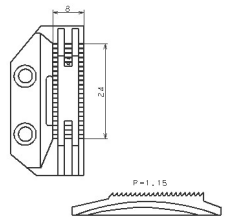
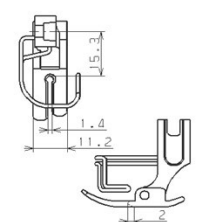
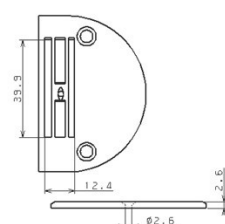
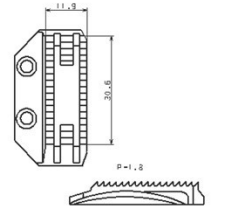
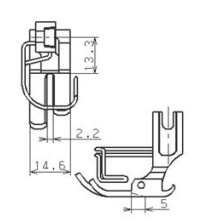
C/N	针板		传送齿		压脚(组件)		注释
	品号	形状	品号	形状	品号	形状	
45	1345	B1109552000	B1613012100		D1524555DBA		面向一般出口、中国薄料规格标准、针板以英寸表示
							
46	1346	11400801	11403003		D1524555EBL		DDL8700-7 H规格标准、针板的针孔前后有避让
							
47	1347	11062007	11062601		D1524126WBA		面向中国、一般出口、欧州 L规格标准、特氟龙压脚
		